

8 7 6 5 4 3 2 1

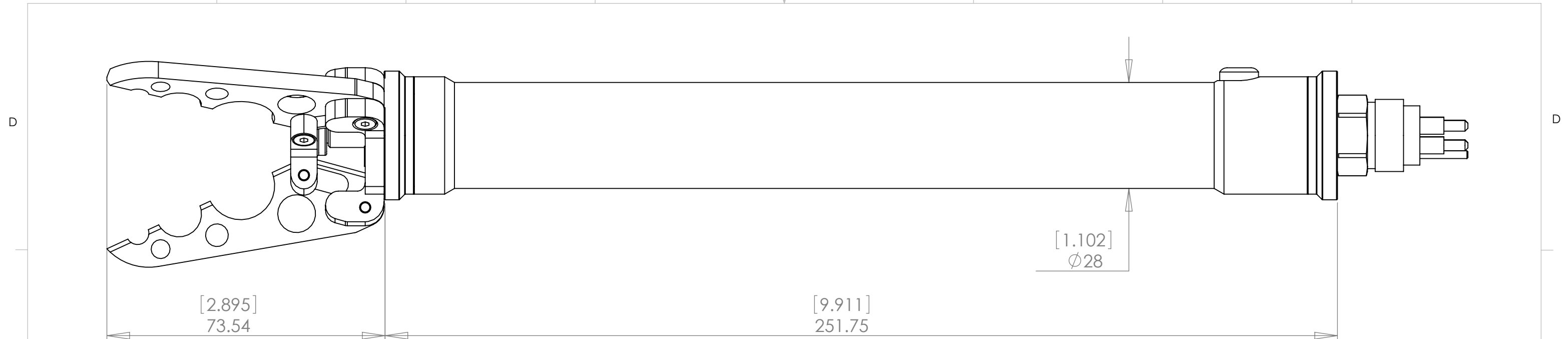

C



### TJG301 SPECIFICATIONS

**DEPTH RATING**

SEA WATER: 300 METERS - 1,000 FEET

**MOTOR & GEARBOX**

MOTOR: MAXXON  
 GEARBOX: MAXXON  
 TORQUE: 0.8 Nm  
 DRIVE MECHANISM: LEAD SCREW

**ELECTRICAL INTERFACE**

VOLTAGE: +28V DC ±10%  
 CONNECTOR: SUBCONN PART# BH4M  
 4 PIN (POWER, COMMON, CLOCK & DATA)

**WEIGHT**

IN AIR: 350 GRAMS - 0.77LBS  
 IN FRESH WATER: 235 GRAMS - 0.52LBS

**PERFORMANCE**

GRIPPING FORCE: 6.5 KGF - 14 FT/LBS  
 MAXIMUM OPENING DIAMETER: 55 MM - 2.2 IN

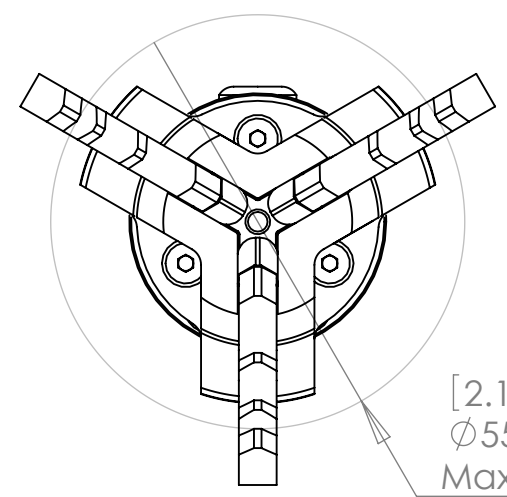

Front View

[2.156]  
 Ø55  
 Max Jaw Opening

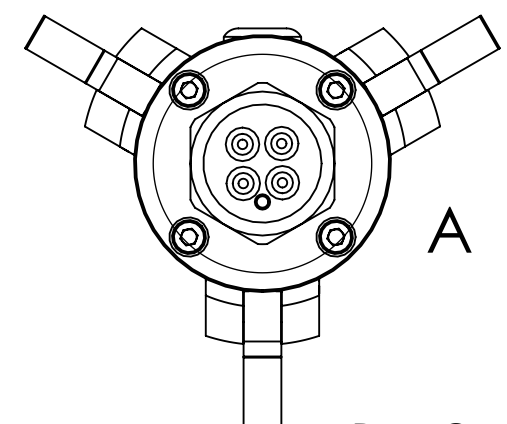

Rear Connector

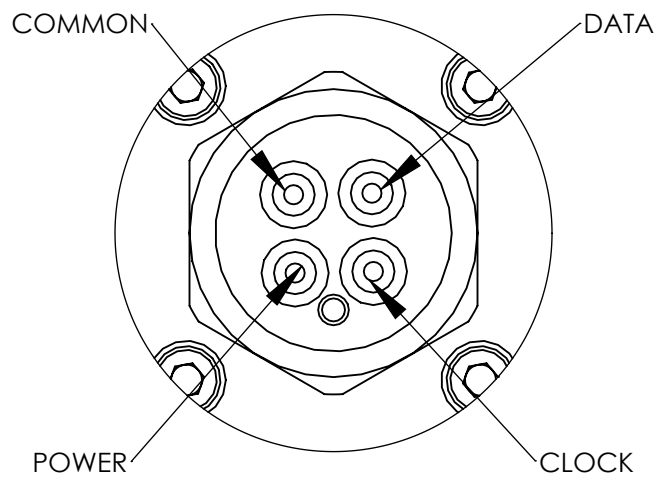

DETAIL A  
 SCALE 2 : 1

Material	6061 Aluminum	NAME	Jesse	DATE	1 JAN07
Finish	Hard Anodized	DRAWN			
		CHECKED			
		ENG APPR.			

**SeaBotix Inc.**  
 1425 Russ Blvd, T112D  
 San Diego, CA 92101  
 USA

PROPRIETARY AND CONFIDENTIAL  
 THE INFORMATION CONTAINED IN THIS DRAWING IS THE SOLE PROPERTY OF SeaBotix Inc.. ANY REPRODUCTION IN PART OR AS A WHOLE WITHOUT THE WRITTEN PERMISSION OF SeaBotix Inc. IS PROHIBITED.

COMMENTS:  
 UNLESS OTHERWISE SPECIFIED  
 BREAK ALL EDGES R/C 0.01  
 NO BURR ALLOWED.  
 DO NOT SCALE DRAWING.  
 ALL DIMENSIONS APPLY AFTER FINISH.

TITLE: <b>Three Jaw Grabber</b>		
SIZE <b>B</b>	PART. NO. <b>TJG301</b>	REV <b>A</b>
SCALE: 1:1	WEIGHT:	SHEET 1 OF 1

A

8 7 6 5 4 3 2 1