

8 7 6 5 4 3 2 1

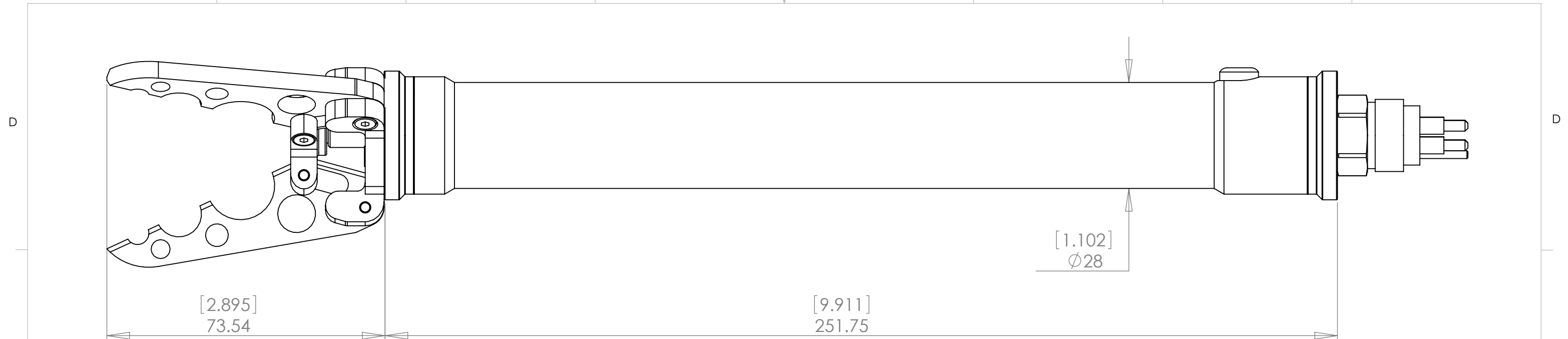

C



TJG301-2 SPECIFICATIONS

DEPTH RATING	
SEA WATER:	300 METERS - 1,000 FEET
MOTOR & GEARBOX	
MOTOR:	MAXXON
GEARBOX:	MAXXON
TORQUE:	0.8 Nm
DRIVE MECHANISM:	LEAD SCREW
ELECTRICAL INTERFACE	
VOLTAGE:	+24V DC ±10%
CONNECTOR:	SUBCONN PART# BH4M 2 PIN (POWER & COMMON)
WEIGHT	
IN AIR:	350 GRAMS - 0.77LBS
IN FRESH WATER:	235 GRAMS - 0.52LBS
PERFORMANCE	
GRIPPING FORCE:	6.5 KGF - 14 FT/LBS
MAXIMUM OPENING DIAMETER:	55 MM - 2.2 IN

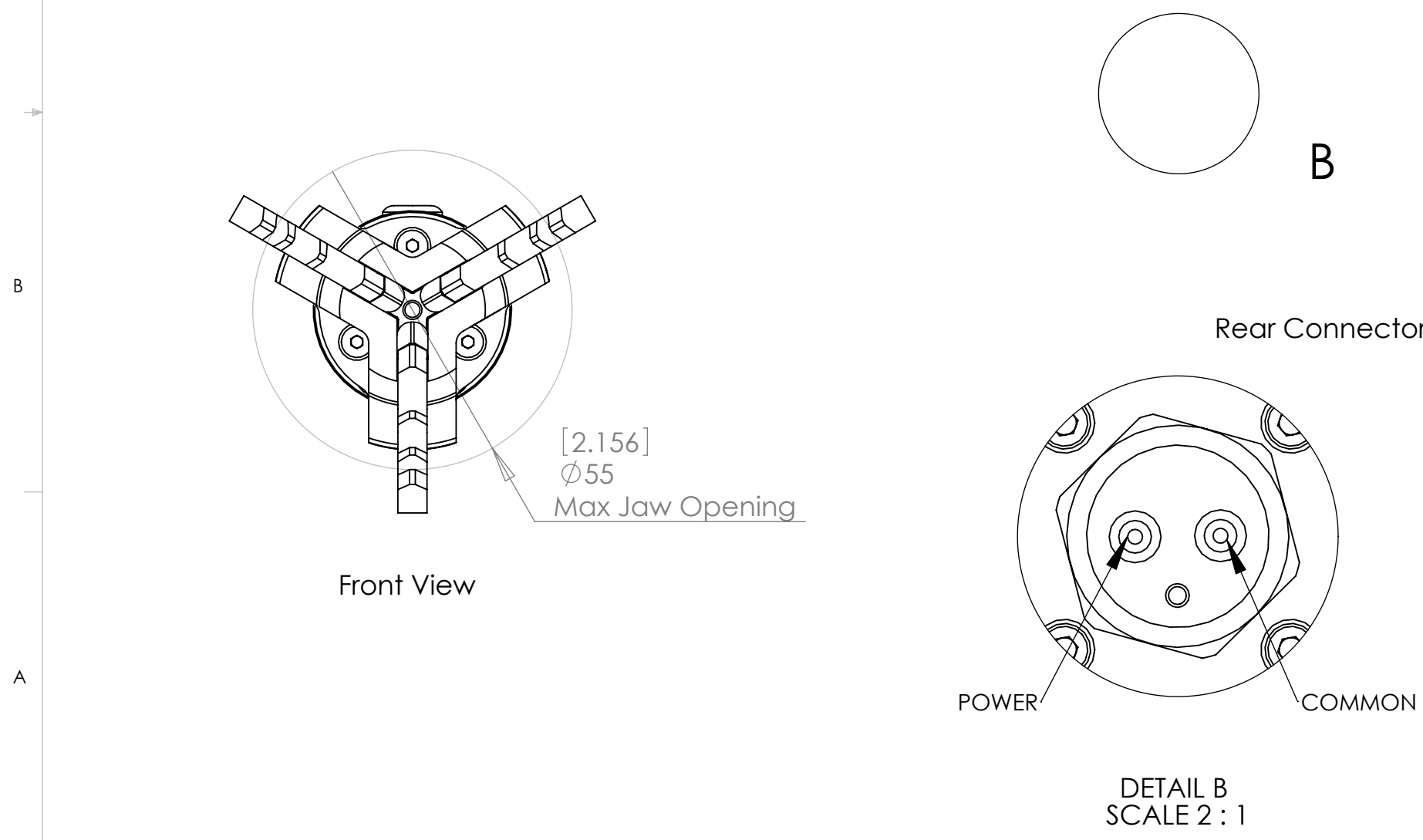

B

Material	6061 Aluminum	NAME	Jesse	DATE	1 JAN07	SeaBotix Inc. 1425 Russ Blvd, T112D San Diego, CA 92101 USA
Finish	Hard Anodized	DRAWN		CHECKED		
		ENG APPR.				
PROPRIETARY AND CONFIDENTIAL THE INFORMATION CONTAINED IN THIS DRAWING IS THE SOLE PROPERTY OF SeaBotix Inc.. ANY REPRODUCTION IN PART OR AS A WHOLE WITHOUT THE WRITTEN PERMISSION OF SeaBotix Inc. IS PROHIBITED.		COMMENTS: UNLESS OTHERWISE SPECIFIED BREAK ALL EDGES R/C 0.01 NO BURR ALLOWED. DO NOT SCALE DRAWING. ALL DIMENSIONS APPLY AFTER FINISH.		TITLE: Three Jaw Grabber 2 PIN		
SIZE	B	PART. NO.	TJG301-2	REV	A	
SCALE: 1:1		WEIGHT:		SHEET 1 OF 1		

8 7 6 5 4 3 2 1